

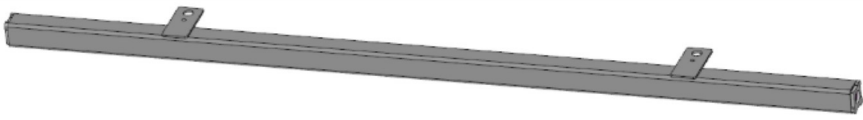

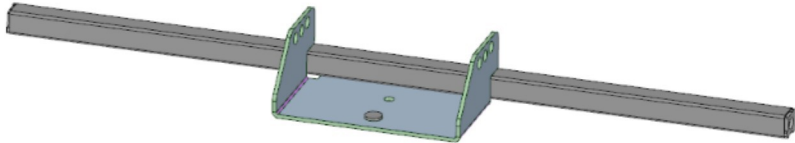

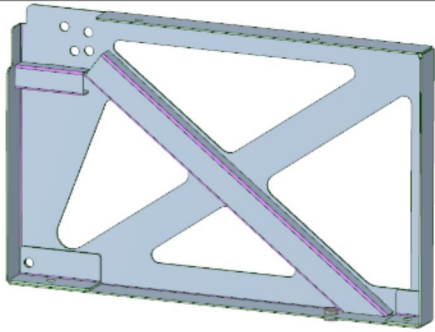

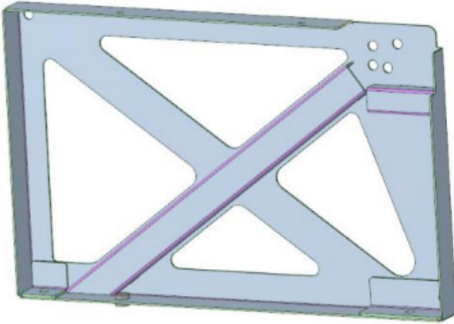

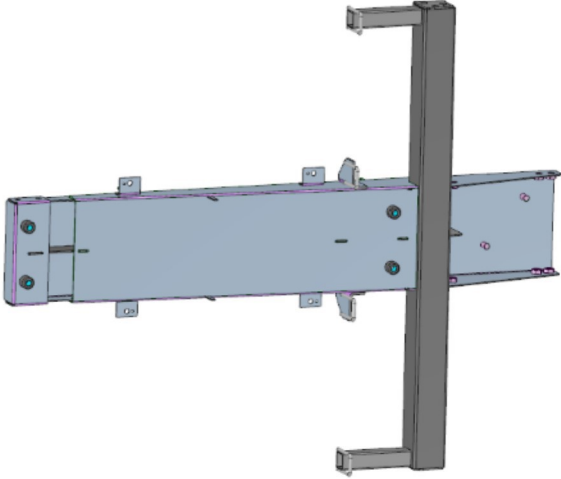
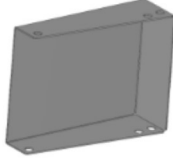



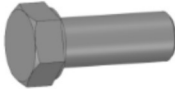
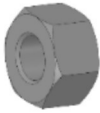



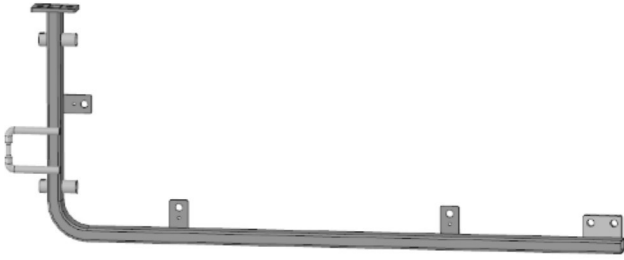

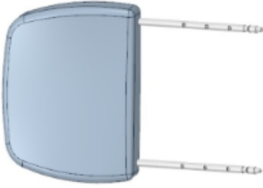
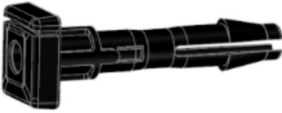

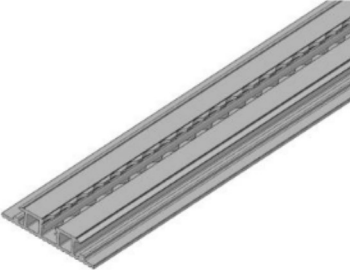
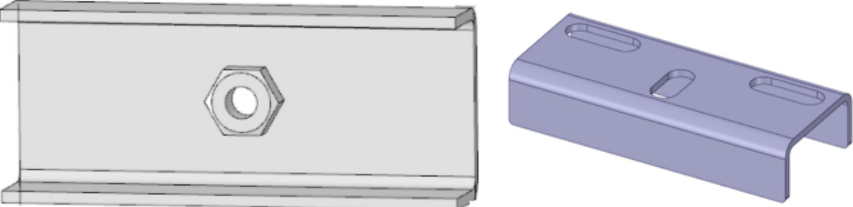

Frame completion list

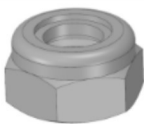
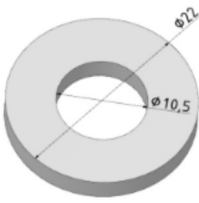
No.	Name	Pcs	View
1	Seat support	1	
2	Lower fixation	1	
3	Left flank	1	
4	Right flank	1	
5	Main frame	1	

6	Bottom cover	1	
7	Bushing	2	
8	Safety belts	2	
9	Press	2	
10	Bolt 7/16" x 28- 20 UNF	6	
11	Nut 7/16"- 20UNF	2	
12	Bolt M10x20 DIN7380 10.9	14	
13	Pad M10 DIN125	14	
14	Pad M12 DIN125	8	

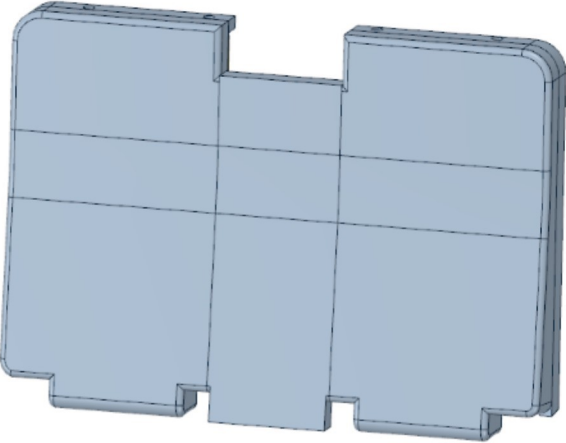
Backrest frame completion list			
No.	Name	Pcs.	View
1	Backrest frame left	1	
2	Backrest frame right	1	
3	Headrest	2	
4	Sleeve headrest	4	
5	Pad M8 DIN125	4	
6	Bolt M8x25 DIN7380 8.8	4	
7	Bolt M8x25 DIN7991 8.8	4	

Frame fixation completion list			
L.p	Nazwa	Ilość	Obrazek
1	Aluminium Rail 980mm	3	
2	Underfloor rainforment WZP-01	6	
3	TMI-17	5	
7	Nut M10 DIN985	5	
8	Pad M10 DIN9021	5	
9	Bolt DIN912 M10x45 8.8	6	

Upholstery completion list			
L.p	Nazwa	Ilość	Obrazek
1	Seat	1	
2	Backrest	1	
3	Pad M5 DIN9021	16	
4	Bolt M5x25 DIN912	16	
5	Wood screw	16	

MAIN FRAME

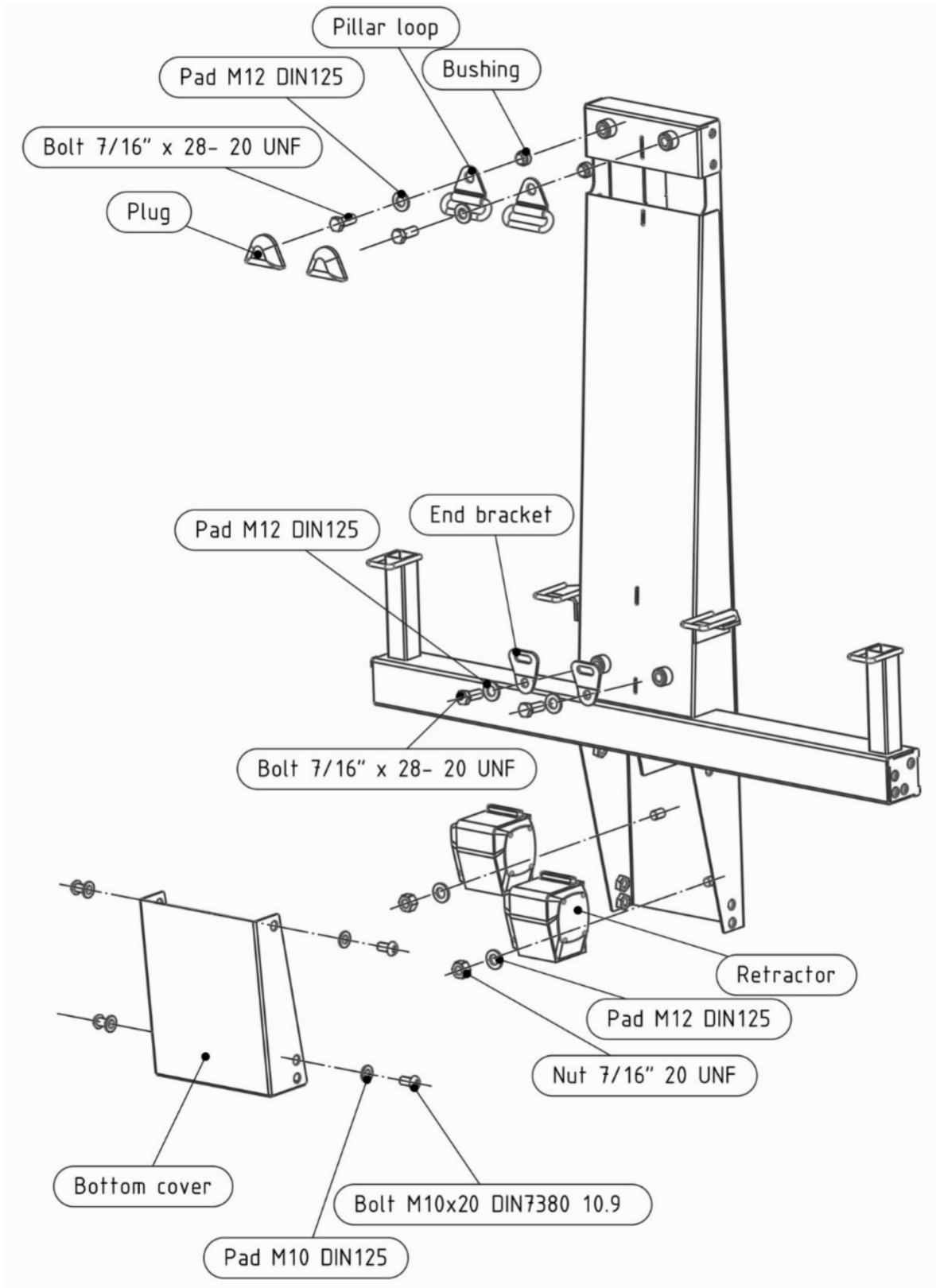

FRAME ASSEMBLY

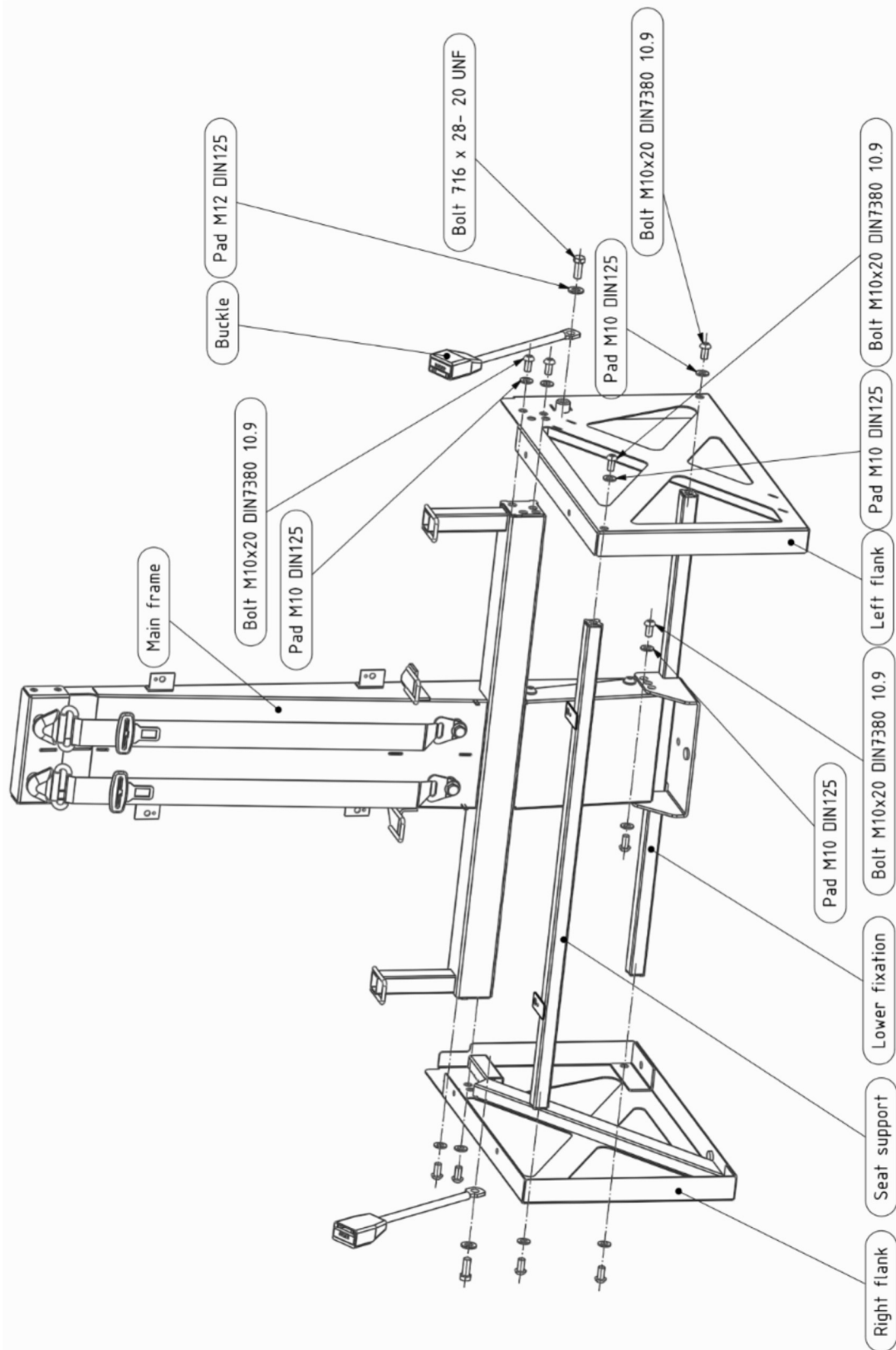

ANGLE REGULATION

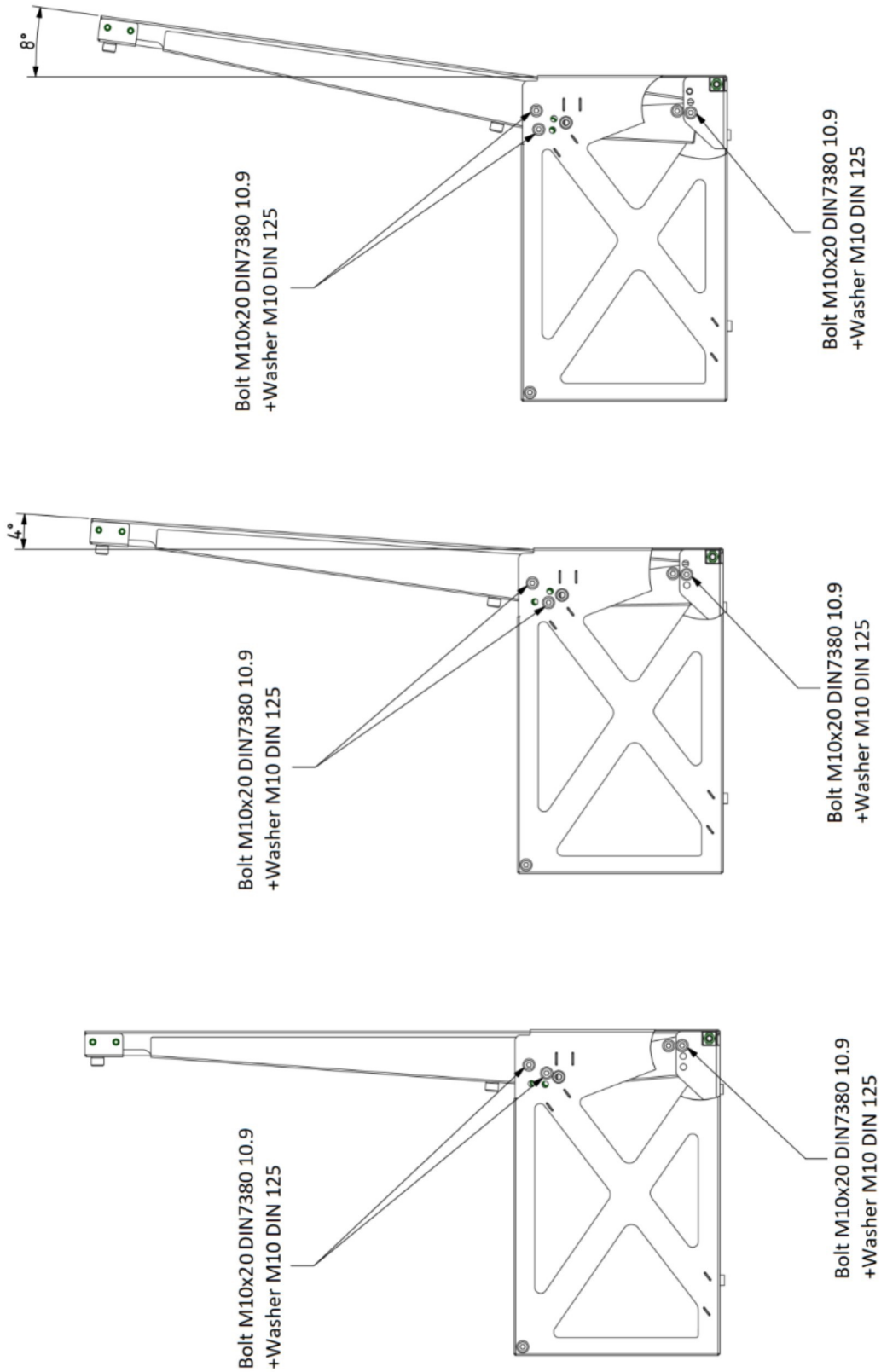

BACKREST FRAME

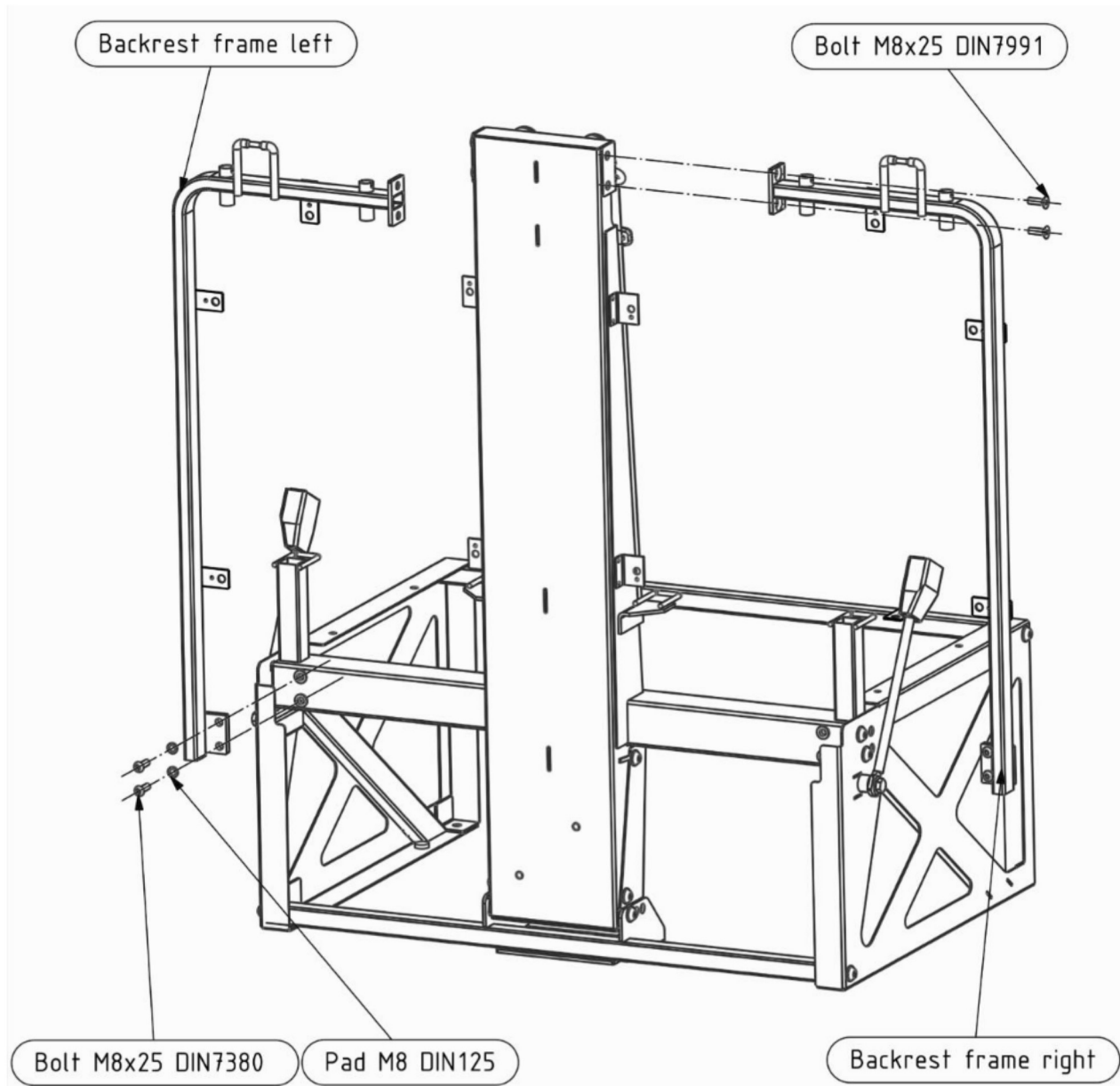

UPHOLSTERY

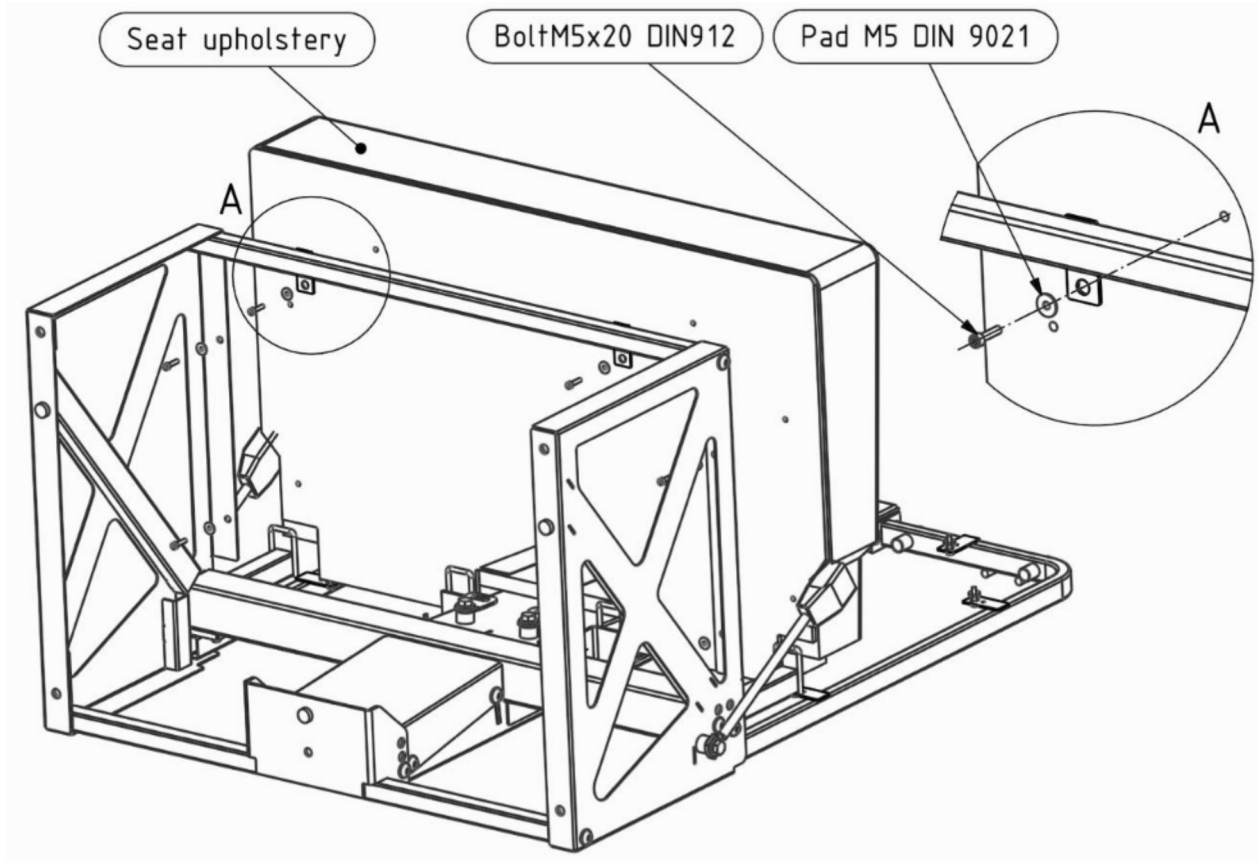

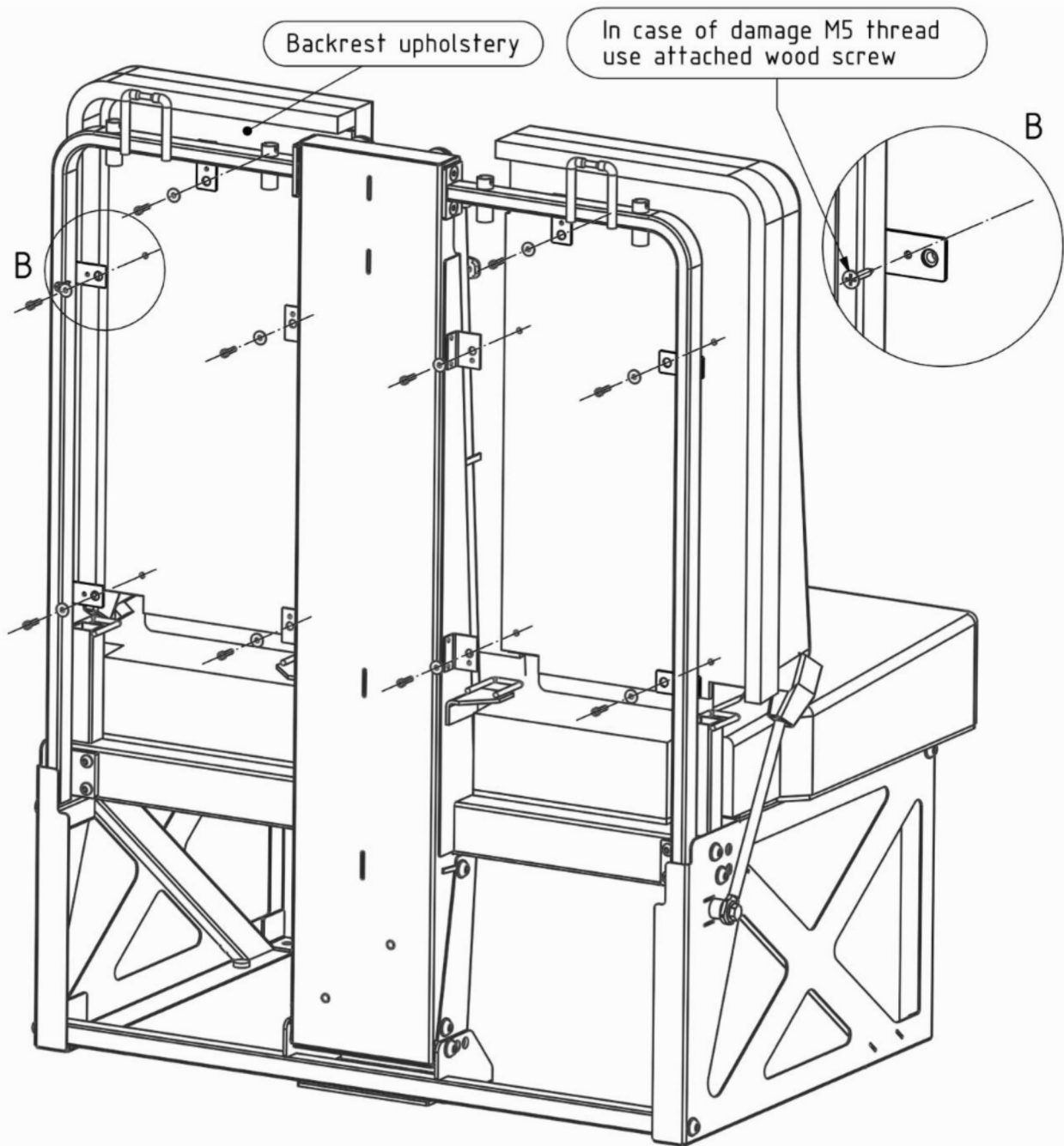

HEADRESTS

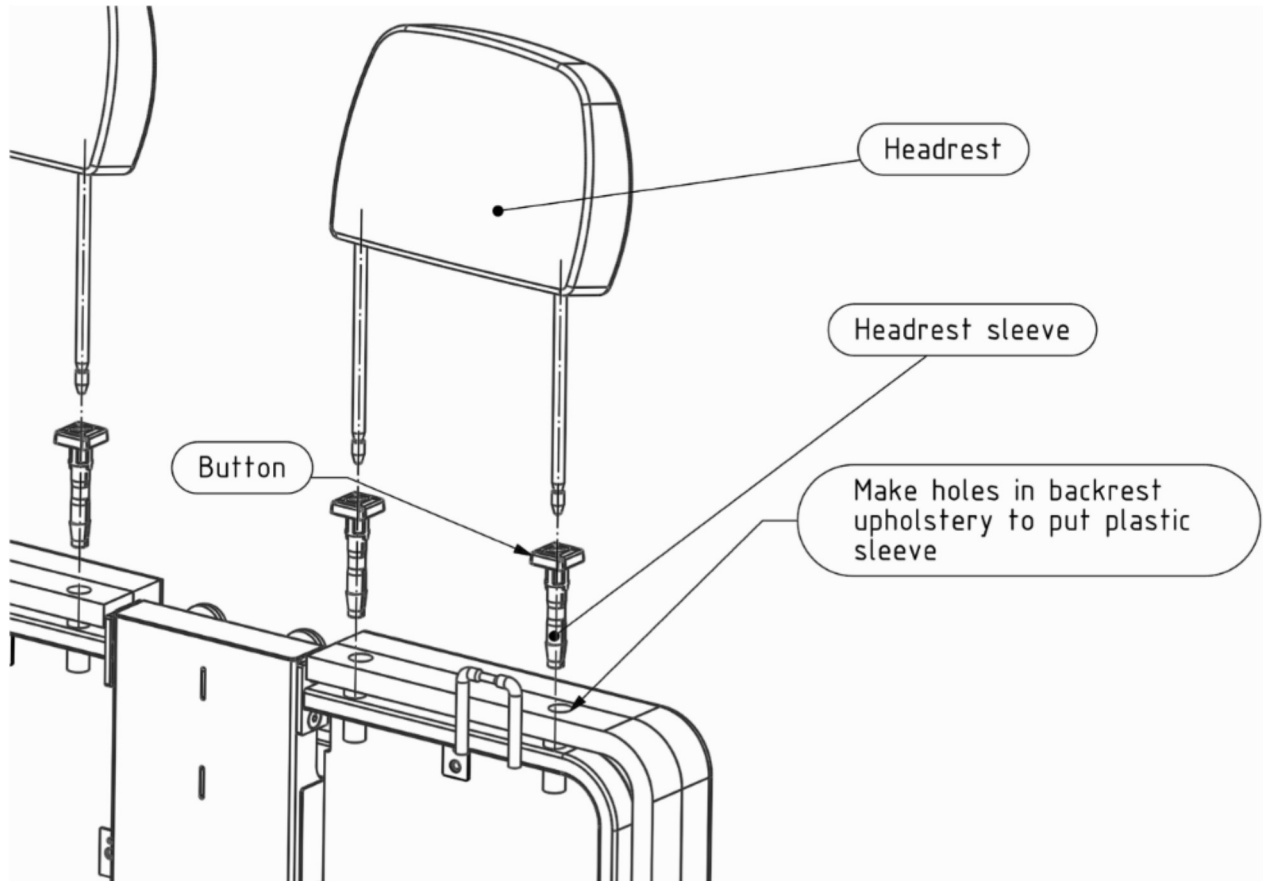

NON STANDARD POSITIONING IN THE ALUMINIUM RAILS

STEP 1

Keep both of below positioning conditions:

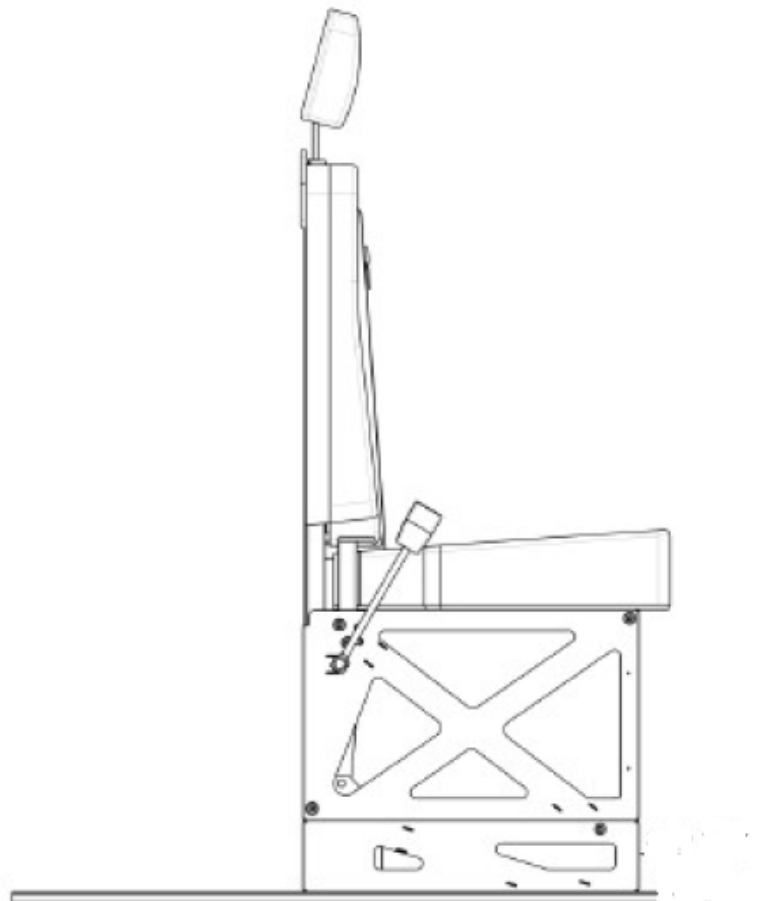
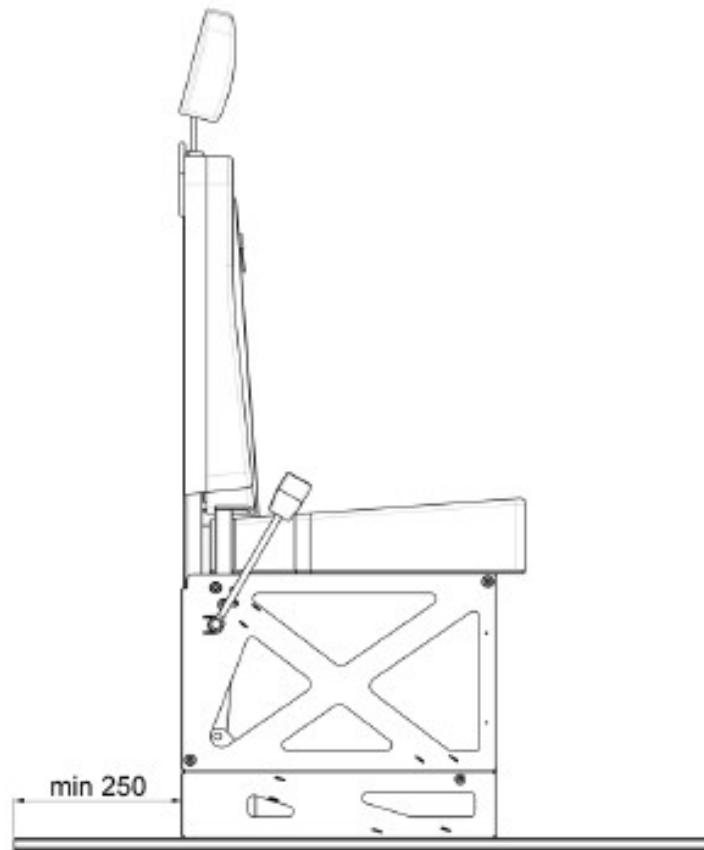

RAILS INSTALLATION

Surface preparation of:

- raw or coated aluminum
 - originally or powder coated steel sheet
- 1) roughen
 - 2) degrease with Sika Aktivator 205 or BETACLEAN 3350
 - 3) prime with Sika 206G+P or BETAPRIME 5061

For surfaces prepared in this way, apply 1 path of Sikaflex 252 or 552 or BETAMATE 7120 in an S pattern. In the fragment of the vehicle floor, where adhesive is applied, use (in several places, spot) separators (e.g. washer) of ~3 mm thickness, and afterwards attach and press the rail. If there necessary use distances to keep flatness of rail.

In the rear part of the rail (30 ÷ 60 mm from rail's rear end) there must be one underfloor reinforcements – C-profiles WZP-01 (fixed by M10-8.8 bolt). We also recommended using WZP-01 in front of rail but this is not necessarily.

